

SDV35-N

Direct Vent Fireplaces Millivolt - Natural Gas

- Includes Fuel Conversion Kit (to Propane Gas)
- Suitable for Manufactured Home Installations
- Many Options Available - Blowers, Remotes, Wall Switch, Wall Thermostat, Screen Door, Brick Liners, Trim Kits and more.

Product Reference Information			
Cat. No.	Model	Shipping Weight	Shipping Volume
H4632	SDV35-N	115 lb.	16.17 cu. ft.

Framing Dimensions - Inches (millimeters)					
Model	A	B	C	D	E
SDV35	41-1/4 (1048)	37-1/2 (953)	23-3/4 (603)	41-1/8 (1045)	16" (406)

Input (BTU/HR)		
Natural (NG) & Propane (LP) Gas		
Model	Fuel	Input Rate (BTU / HR)
SDV35	NG	High 23,000; Low 17,500
	LP	High 23,000; Low 17,500

Efficiencies %						
Model	Natural Gas			Propane		
	EnerGuide	Steady State	AFUE	EnerGuide	Steady State	AFUE
SDV35	55	67	63	60	68	64

Wall Framing Specifications

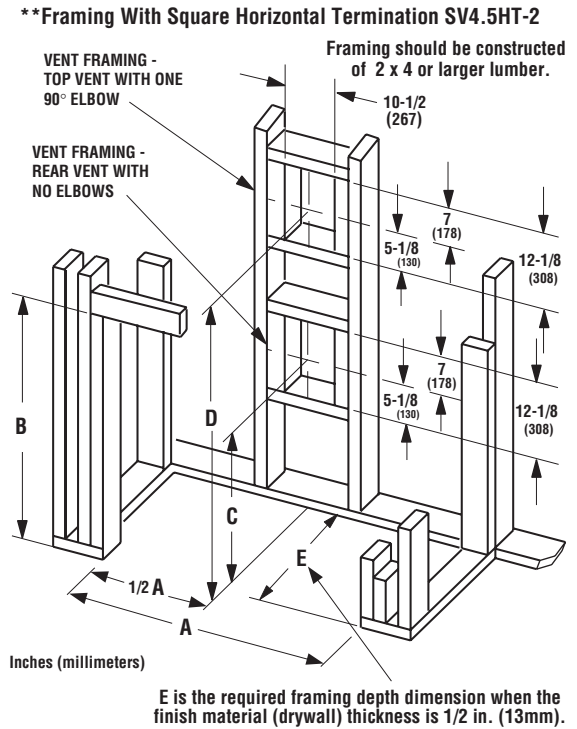

Framing Dimensions & Specifications

Roof Framing Dimensions

Framing Dimensions Roof	
PITCH	Parallel to Framing
0/12	10 1/2 in. (267 mm)
6/12	10 1/2 in. (267 mm)
12/12	10 1/2 in. (267 mm)
PITCH	Perpendicular to Framing
0/12	10 1/2 in. (267 mm)
6/12	12 in. (305 mm)
12/12	17 3/4 in. (451 mm)

(See Ceiling Framing on Page 2)

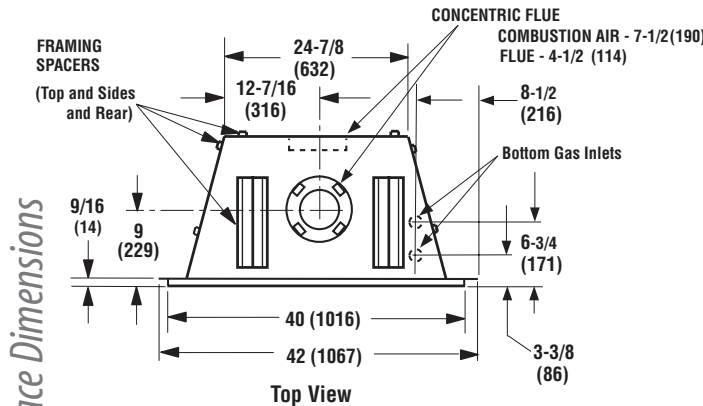

Fireplace Dimensions

Note: J-box can be relocated in either the right front or left front corners of appliance by relocating the moveable J-box plate.

Vent Size	
Co-axial DV Vent Size	4-1/2" Inner 7-1/2" Outer

Notes	
⊗ The Steady State Efficiency numbers based on maximum vent configuration.	
Due to Lennox' ongoing commitment to quality, all specifications, ratings and dimensions are subject to change without notice.	

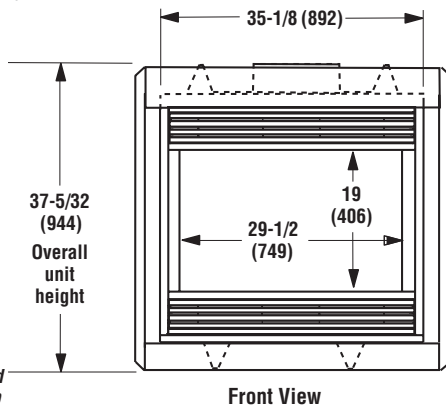

NOTE - Hood shown as positioned in louvered front model.

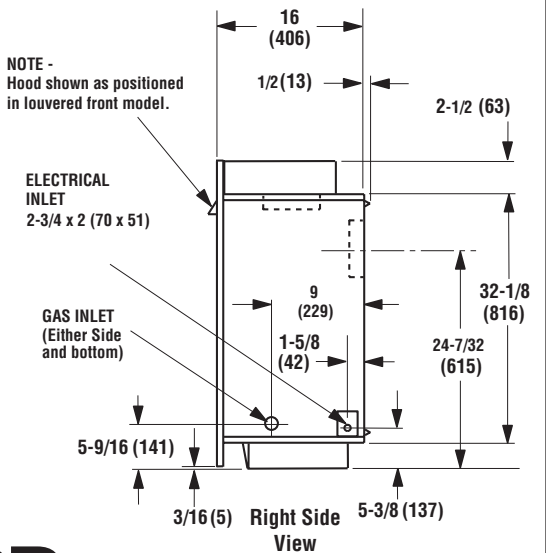

Listing Information

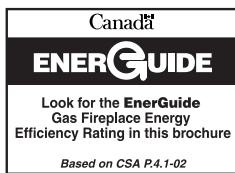

Tested & Listed By **OTL** Beaverton Oregon USA
OMNI-Test Laboratories, Inc.

These fireplaces have been tested and listed by OMNI-Test Laboratories to ANSI Z21.88b

OTL Report No. 116-F-29-5

SDV35-N

Direct Vent Fireplaces Millivolt - Natural Gas

Mantel Clearances

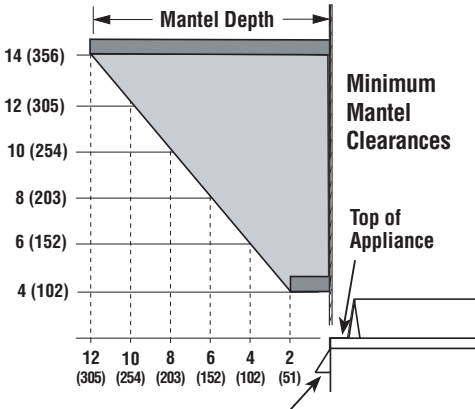

Note - Hood shown as positioned with louvered panels.

Venting

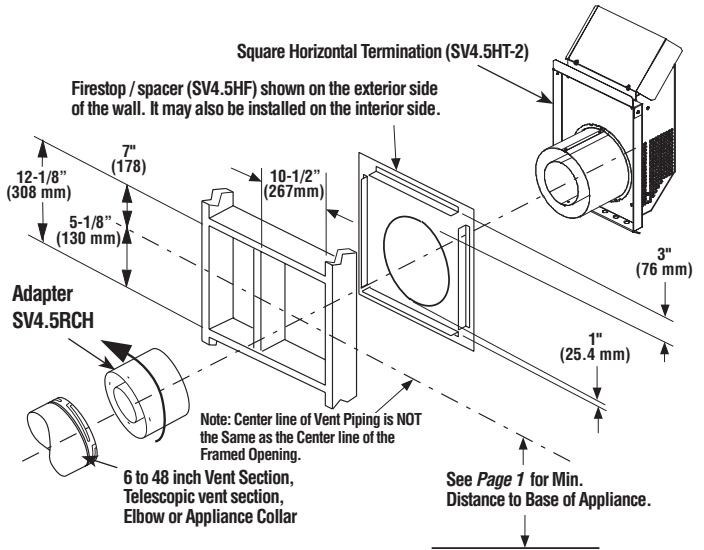

Specifications and clearances are subject to change without notice. Refer to Installation Manual before installation of these appliances for updated dimensions and instructions.

Appliance Clearances

MINIMUM CLEARANCES	
Back	1/2 (13) 0 (0) Spacers
Sides	1/2 (13) 0 (0) Spacers
Top Spacers	0 (0)
Floor	0 (0)
Bottom of Appliance To Ceiling	64 (1626)
Vent	3 (76) Top * 1 (25.4) Sides & Bottom
SERVICE CLEARANCES Feet (meters)	
Front	3 ft. (0.9 m)

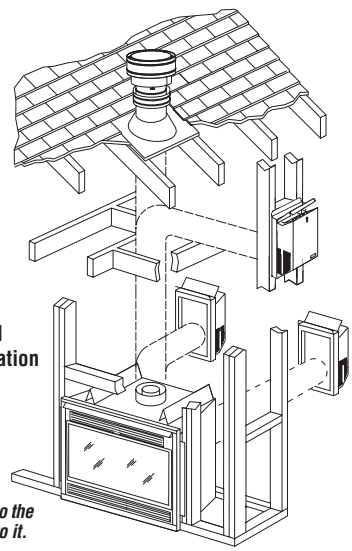
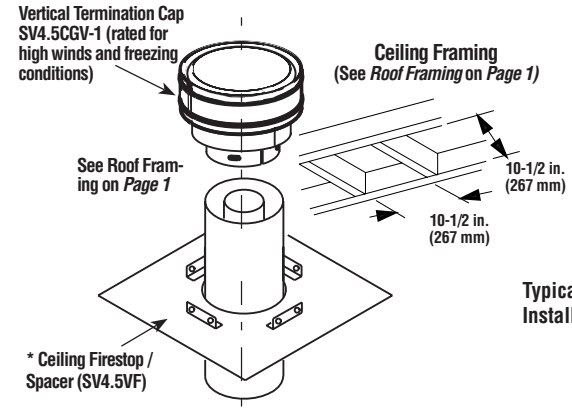

*Note: 3 in. (75 mm) above any horizontal/inclined vent component.
**Note: See Installation Manual, Page 9, Step 1 for clearance requirements to the nailing flange located at each side of the unit and any screw heads adjacent to it.

Minimum Distance to Unprotected Side Wall

Combustible materials may project beyond the sides of the fireplace opening as long as they are kept within the shaded areas illustrated here.

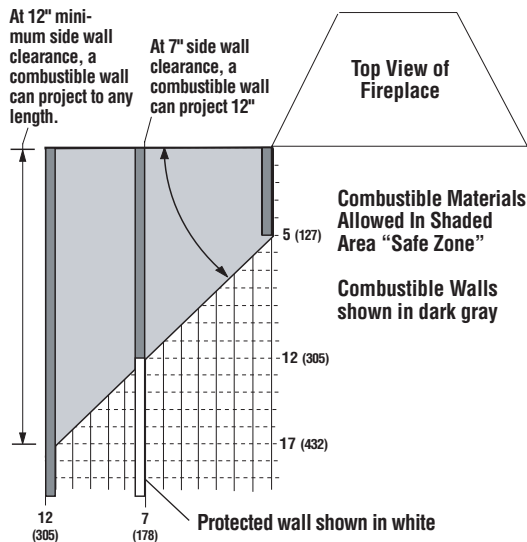

Shelf Height

Model No.	Combustible Shelf Height - Inches (millimeters)			
	Top Vent - with One 90 Degree Elbow		Rear Vent - Straight Out the Back	
	Secure Vent	Secure Flex (flex elbow)	Secure Vent	Secure Flex
SDV35	*48-5/8 (1235)	*50-3/8 (1280)	37-1/2 (953)	37-1/2 (953)

* Includes 3" clearance to combustibles (required above vent components)

